

Altra-Air Fan

INSTALLATION MANUAL METRIC HARDWARE



92 Railway St. Box 668
Seaforth, Ontario, Canada NOK 1W0

Tel: (866)771-7766 or (519)527-2198
Fax (519) 527-2560

www.enviranorth.com

Fan Components

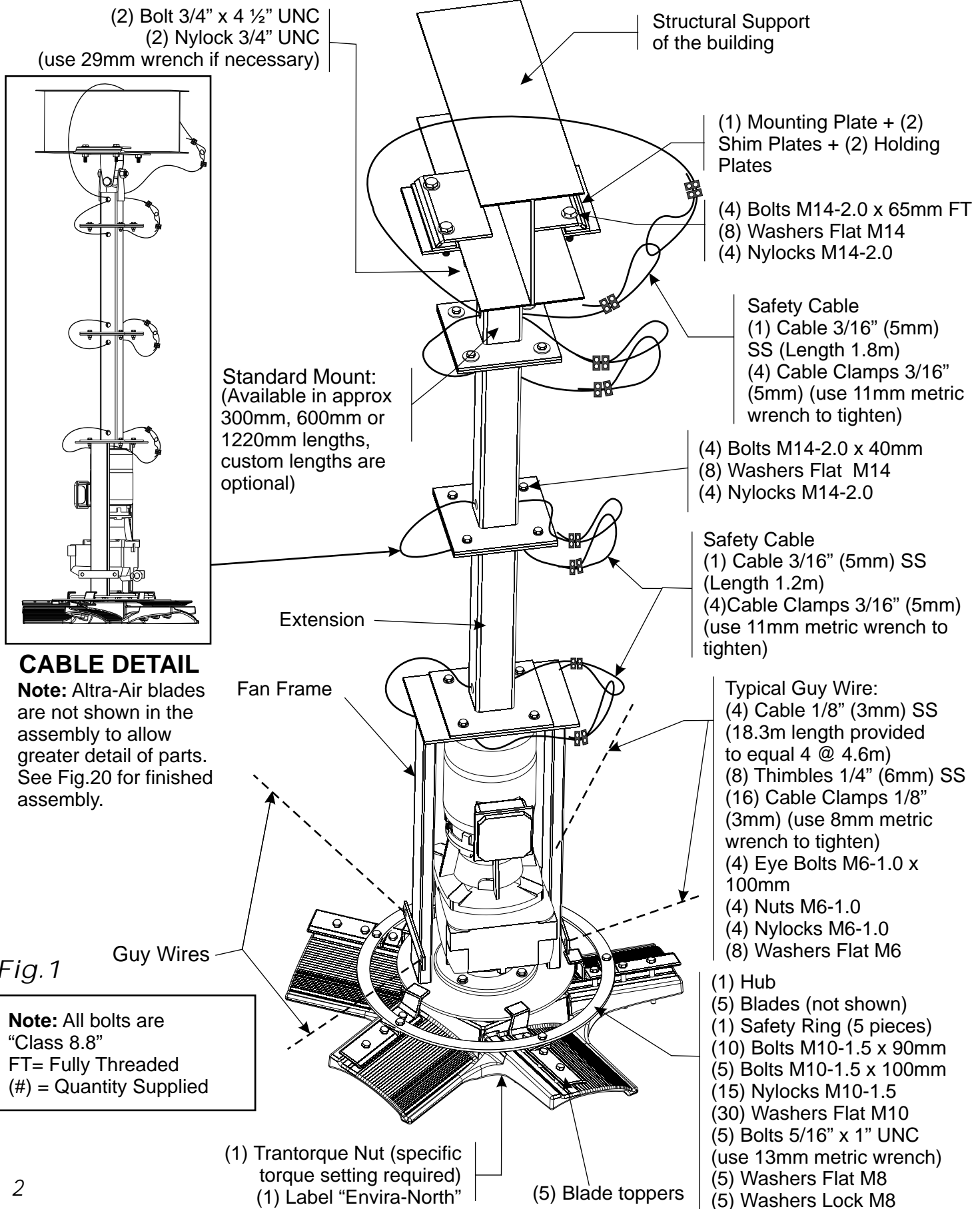
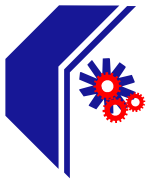

Fig. 1

Note: All bolts are "Class 8.8"
FT= Fully Threaded
(#) = Quantity Supplied



Index

1/ Tools required to install product.....	Pg.4
2/ Required steps before installation.....	Pg.4
3/ Different Mounting Applications.....	Pg.4
• "I" Beam (<i>Fig.2</i>)	
• OWSJ (<i>Fig.3</i>)	
• Wood Beam (<i>Fig.4</i>)	
• Concrete Beam (<i>Fig.5</i>)	
• Purlin "Z" Mount (<i>Fig.6</i>)	
4/ Standard Mount.....	Pg.7
• What is included in the mount package	
• What standard mounts are available	
• How to install the standard mount (<i>Fig.8</i>)	
• Typical cable clamp installation (<i>Fig.9</i>)	
5/ Extensions.....	Pg.8
• What is included in the extension package	
• What extensions are available (<i>Fig.10</i>)	
• How to install the extensions (<i>Fig.11</i>)	
6/ Main Hub and Drive Assembly.....	Ph.9
• What is included in the main hub and drive assembly	
• How to install the assembly (<i>Fig.13</i>)	
• Installing the safety cables (<i>Fig.13</i>) (<i>Fig.9</i>)	
7/ Guy Wires.....	Pg.10
• What is included in the guy wires	
• How to install the guy wires (<i>Fig.9</i>) (<i>Fig.14</i>) (<i>Fig.15</i>) (<i>Fig.16</i>) (<i>Fig.17</i>)	
• Important leveling instructions	
8/ Blade Assembly.....	Pg.11
• What is included with the blades	
• How to install the blades (<i>Fig.18</i>)	
9/ Safety Ring.....	Pg.12
• What is included with the safety ring	
• How to install the safety ring (<i>Fig.19</i>)	
• Important leveling instructions	
• Complete Assembly (<i>Fig.20</i>)	
Itemized Checklist.....	Pg.13
Maintenance Schedule.....	Pg.14
Safety Precautions.....	Pg.15
Clearance Requirements.....	Pg.16
Maintenance Checklist.....	Pg.17
Warranty and Liability.....	Pg.18
Declaration of Conformity.....	Pg.20

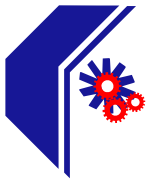

1/ Tools Required to Install Product

- Level
- Cable cutters (for stainless steel aircraft cable)
- Ratchet or impact gun
- Basic metric socket set up to M29
- Basic metric wrench set
- Lifting device or scaffolding

2/ Required Steps Before Installation

- Check to see if you have all the tools required for the installation.
- Verify that all fan components were received.
- Check drawings and layouts provided to locate where the Altra-Air Fan is to be installed.
- Ensure work area is safe and that all security, policies and procedures for the facility are met.
- Inspect the lift device or mobile platform.
- Each person installing the Altra-Air Fan must use a safety harness at all times.
- Other safety requirements may be required for installation.
- All workspace safety requirements, lock out procedures and hoarding of construction zone for the assembly and installation must be met and followed.

Start your installation.

3/ Different Mounting Applications

NOTE: The following mounting applications are representations only and are subject to change without notice. Contact your sales representative or the Envira-North office for complete mounting instructions.

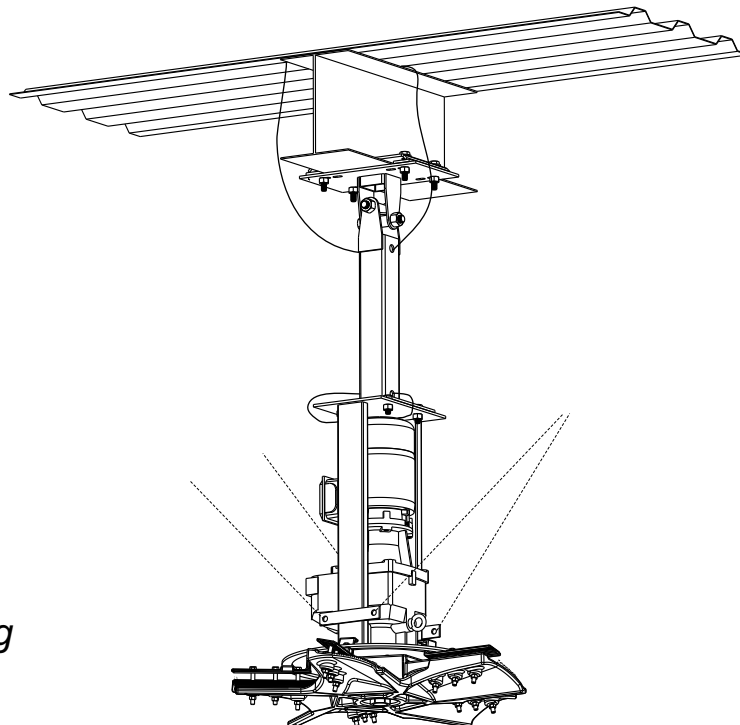

“I” Beam Mounting
Fig.2

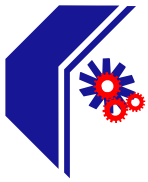

3/ Different Mounting Applications (continued)

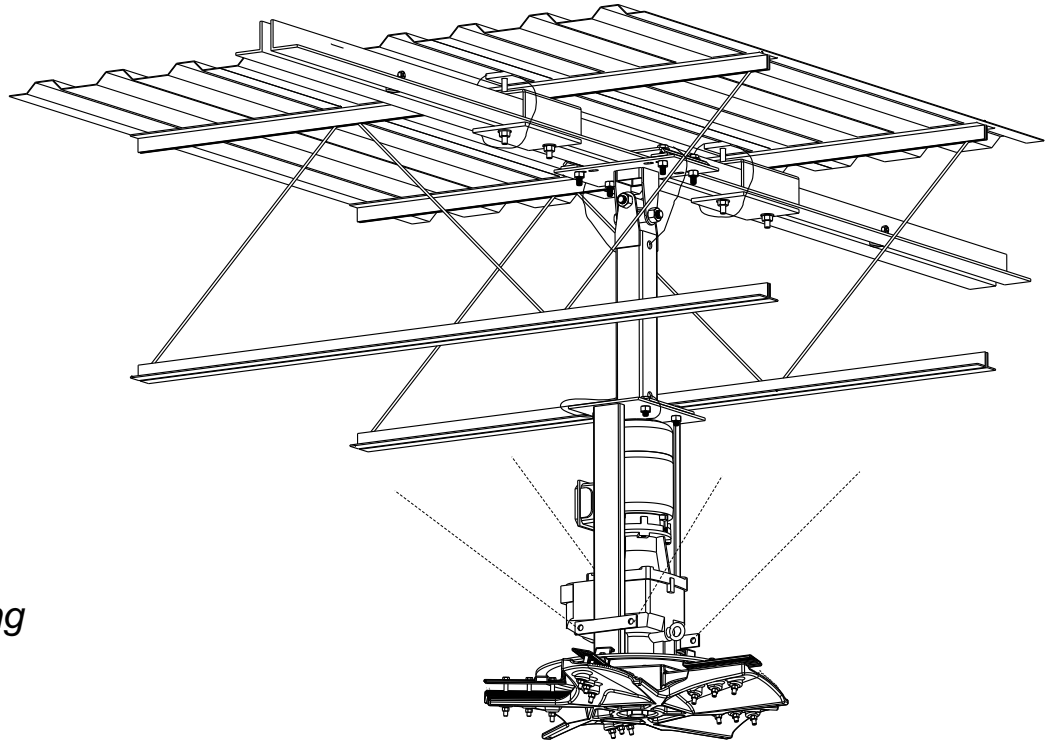

“OWSJ” Mounting
Fig.3

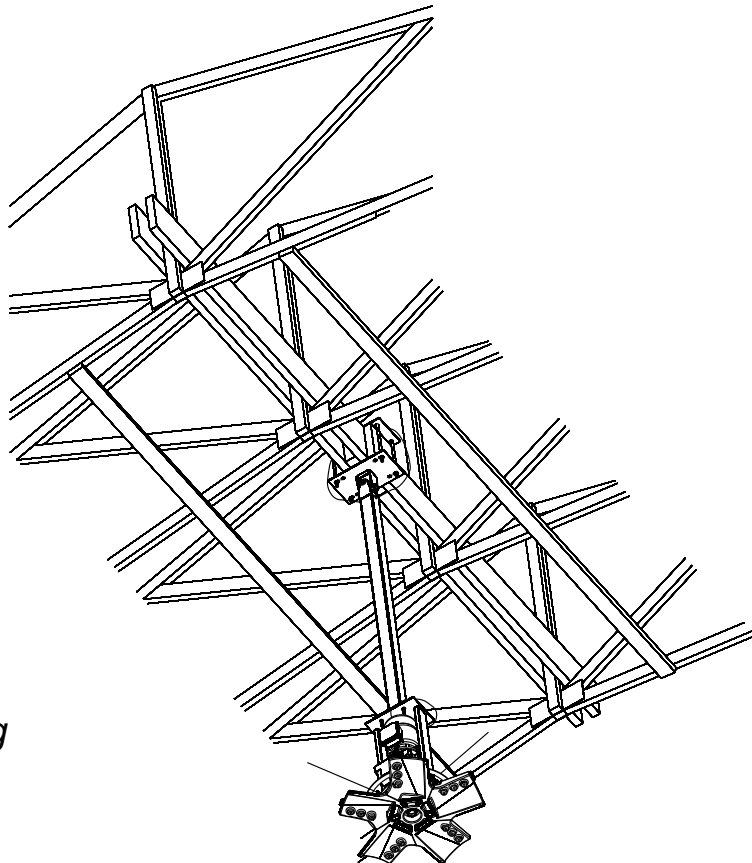

“Wood” Beam Mounting
Fig.4

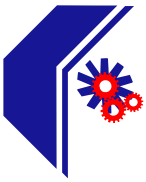

3/ Different Mounting Applications (continued)

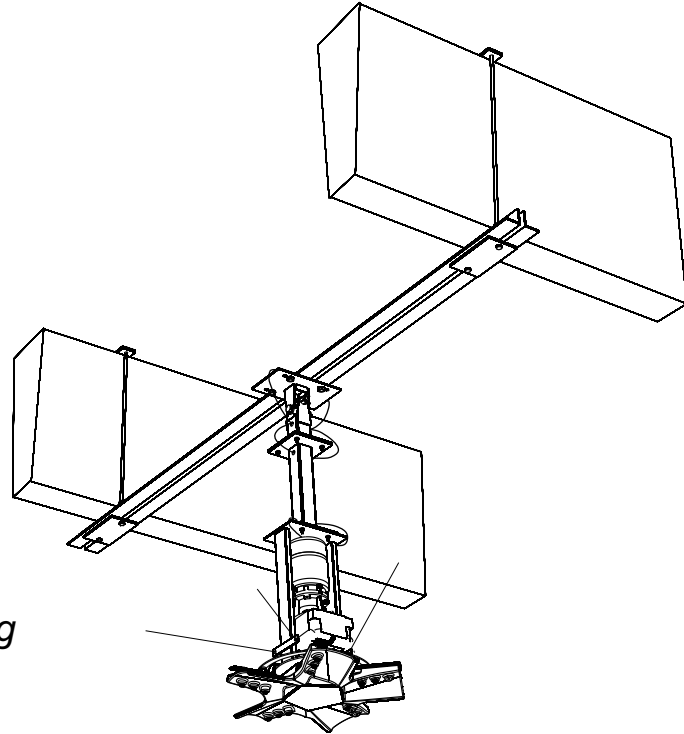

"Concrete" Beam Mounting
Fig.5

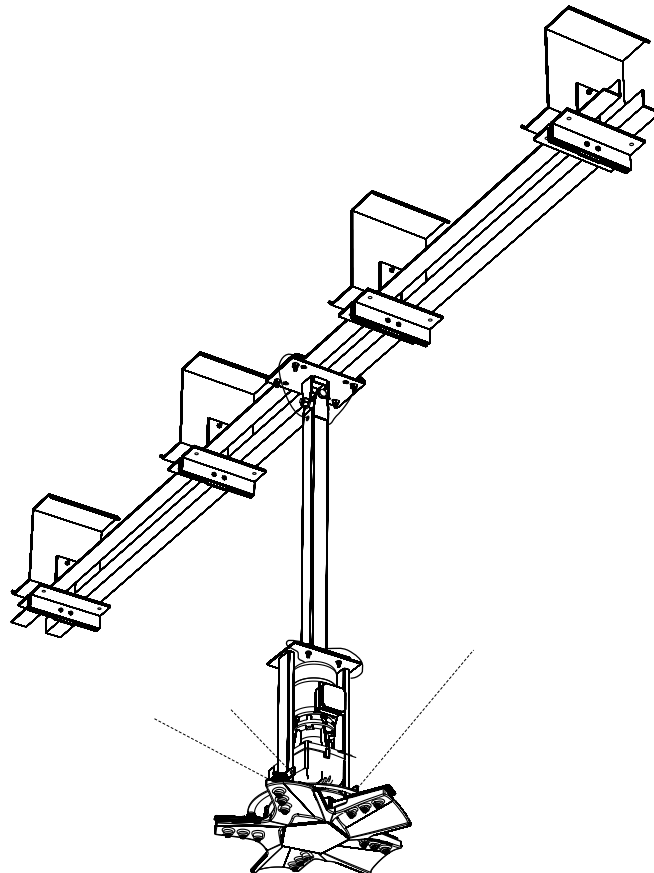

Purlin "Z" Mounting
Fig.6

4/ Standard Mount

A Standard Mount package is used with all Altra-Air Assemblies (except "Wood" Beam Mounting).

Standard drop mounts of approximately 300mm, 600mm and 1220mm are available.

The package includes:

- (2) mfg "I" Beam clamps
- (2) mfg "I" Beam spacers (may or may not be required for assembly)
- (1) Upper Pivot Plate 1 upper Pivot (pre-assembled)
- (1) Stem for 300mm, 600mm & 1220mm packages
- (4) Bolts, Nuts & Washers
- (1) Cable 3/16" (5mm) SS (Length 1.8m)
- (4) Cable Clamps 3/16" (5mm) (not shown)
(use 11mm metric wrench to tighten)

NOTE: Spacer may or may not be required. This is dependent upon the thickness of the support structure.

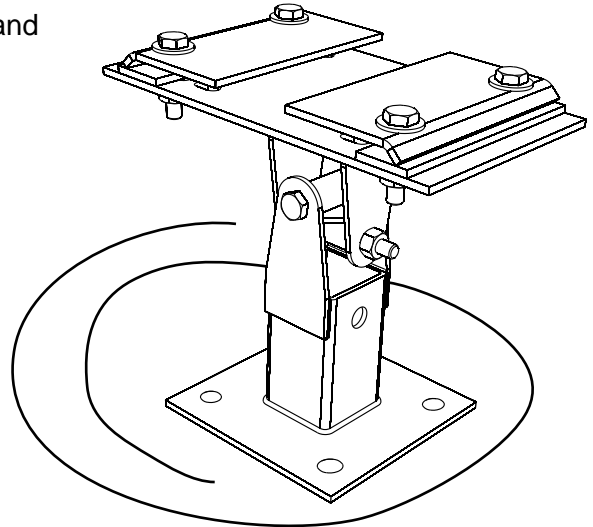

Fig.7

Installing the Mount

1. Sandwich the "I" Beam or OWSJ Beam between the mfg "I" Beam clamps and the upper pivot plate. Insert the mfg "I" Beam spacers if required.
2. Insert the bolts, washers and tighten the nylocks (Fig.8).
3. Position the safety cable as per Fig.8, loop at both ends.
4. Fasten cable clamps as typical cable clamp installation (Fig.9). Cable should be relatively snug.

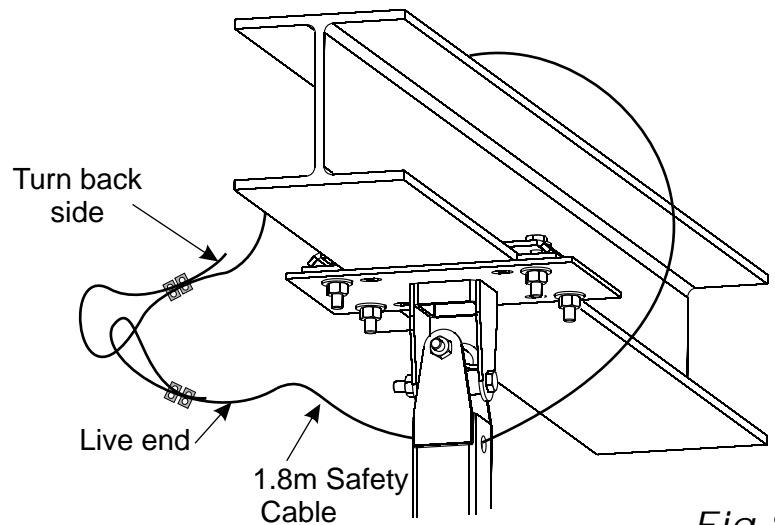

Fig.8

Typical Cable Clamp Installation

When placing cable clamps on the wire, it is imperative that the U-bolt side of the clip is placed on the short turn back side and the saddle goes on the long side (the "live" end).

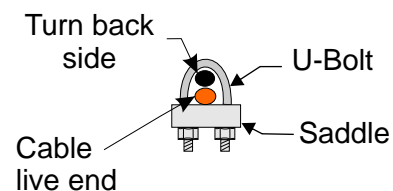
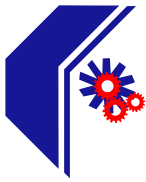

Fig.9



5/ Extensions

The package includes:

- (1) Extension (standard 600mm or 1220mm)
- (4) Bolts M14-2.0 x 40mm
- (8) Washers Flat M14
- (4) Nylocks M14-2.0
- (1) Cable 3/16" (5mm) SS
(Length 1.2m)
- (4) Cable Clamps 3/16" (5mm)
(use 11mm metric wrench to tighten)

Depending on your assembly, your package may include an extension. The extension with the standard mount will make up the overall drop length.

If a specific drop distance is required, a custom extension may be an option and can be ordered.

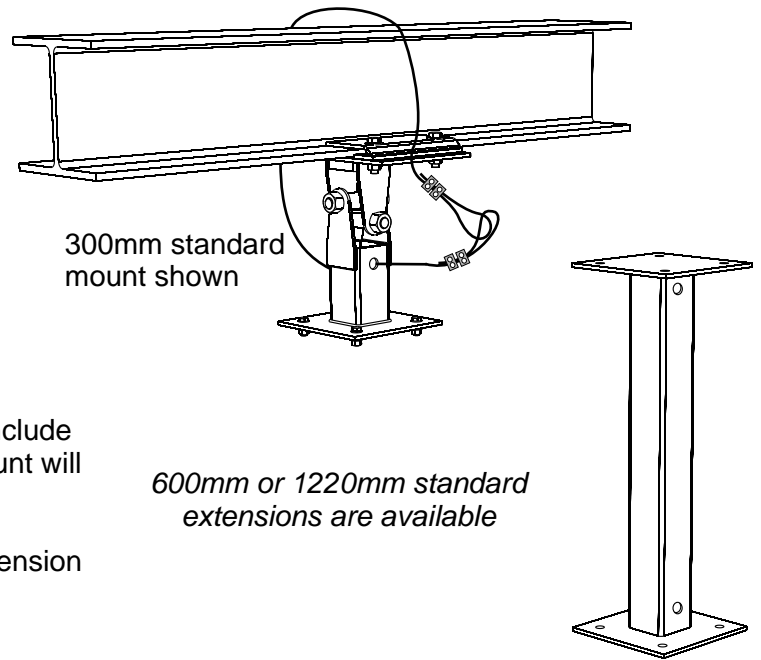

300mm standard
mount shown

600mm or 1220mm standard
extensions are available

Fig.10

You are only allowed to use a maximum of two extensions per assembly!

Installing the Extension

1. Fasten top plate of extension to the bottom plate of the standard mount using M14 bolts, nuts and washers.
2. Position the safety cable as per Fig.11, loop at both ends.
3. Fasten cable clamps 2 per end and as per typical cable clamp installation (Fig.9). Cable should be relatively snug.

Every connection between components (mounts, extensions and fan frame) must include a safety cable as shown throughout this manual, loop at both ends.

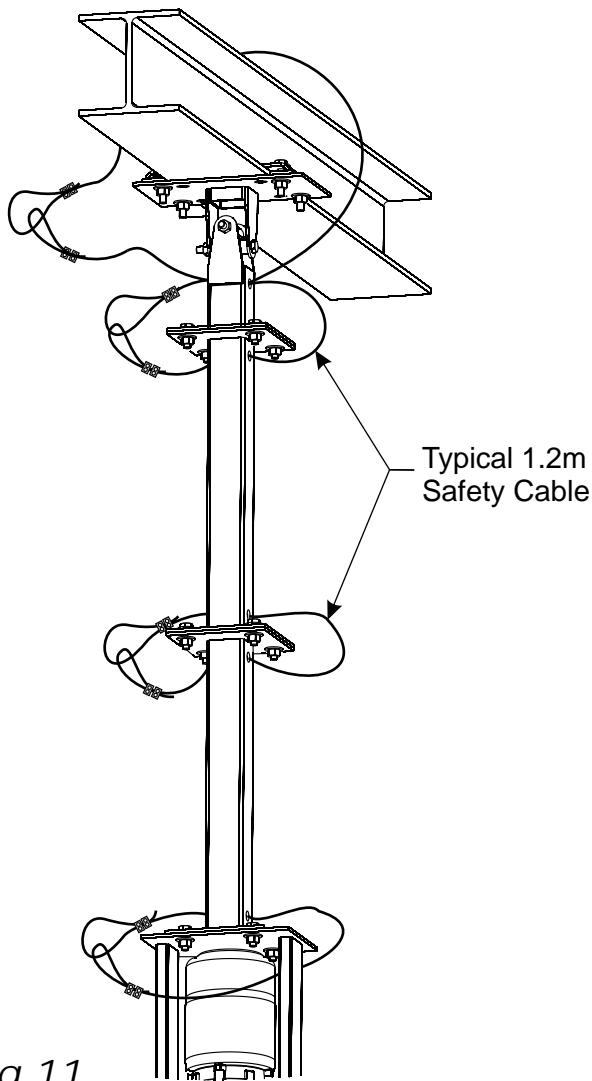
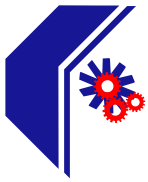

Fig.11



6/ Main Hub and Drive Assembly

The package includes:

- | | |
|--|----------------------------------|
| (1) Hub | All these items
pre-assembled |
| (1) Fan frame | |
| (1) Trantorque nut | |
| (1) Motor | |
| (1) Gear Reducer | |
| (1) Envira-North sign | |
| (4) Bolts M14-2.0 x 40mm | |
| (8) Washers Flat M14 | |
| (4) Nylock M14-2.0 | |
| (1) Cable 3/16" (5mm) SS (1.2m) | |
| (4) Cable clamp 3/16" (5mm)
(use 11mm metric wrench to tighten) | |

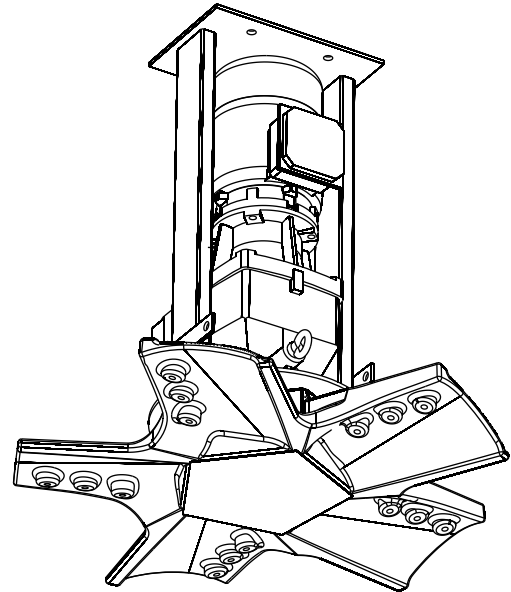

Fig.12

Installing the Main Hub & Drive Assy

1. Fasten top plate of fan frame to the bottom plate of the standard mount using M14 bolts, nuts and washers.
2. Position the safety cable as per Fig.13, loop at both ends.
3. Install and fasten cable clamps 2 per end as per Fig.9. Cable should be relatively snug.

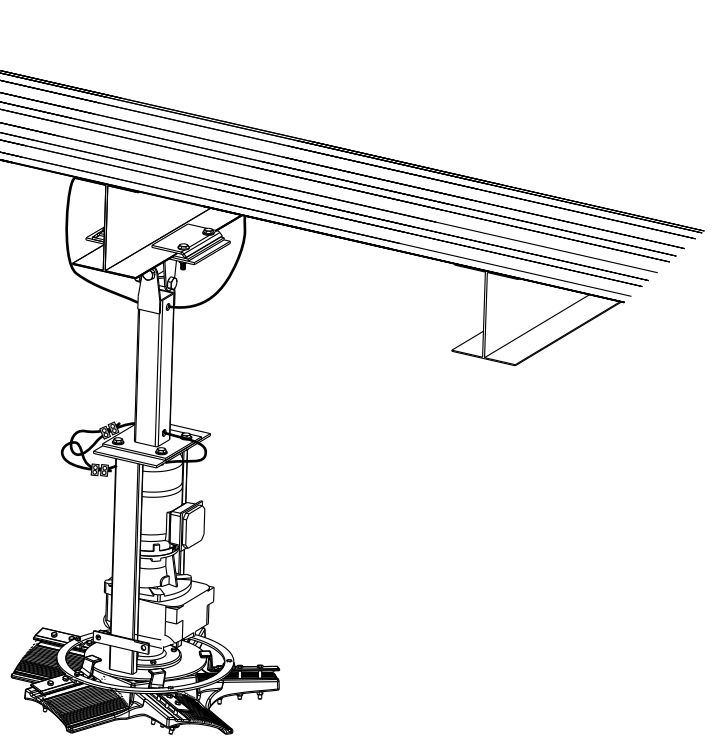

Fig.13

7/ Guy Wires

The package includes:

- (4) Cable 1/8" (3mm) SS (18.3m length provided to equal 4 @ 4.6m)
- (8) Thimbles 1/4" (6mm) SS
- (16) Cable Clamps 1/8" (3mm) (use 8mm metric wrench to tighten)

Extra hardware required:

- (4) Forged Eye Bolts M6-1.0 x 100mm
- (4) Nuts M6-1.0
- (4) Nylocks M6-1.0
- (8) Washers Flat M6

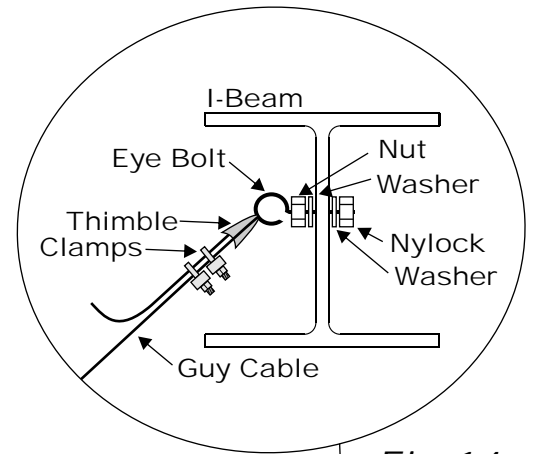

Fig. 14

DO NOT USE TURNBUCKLES

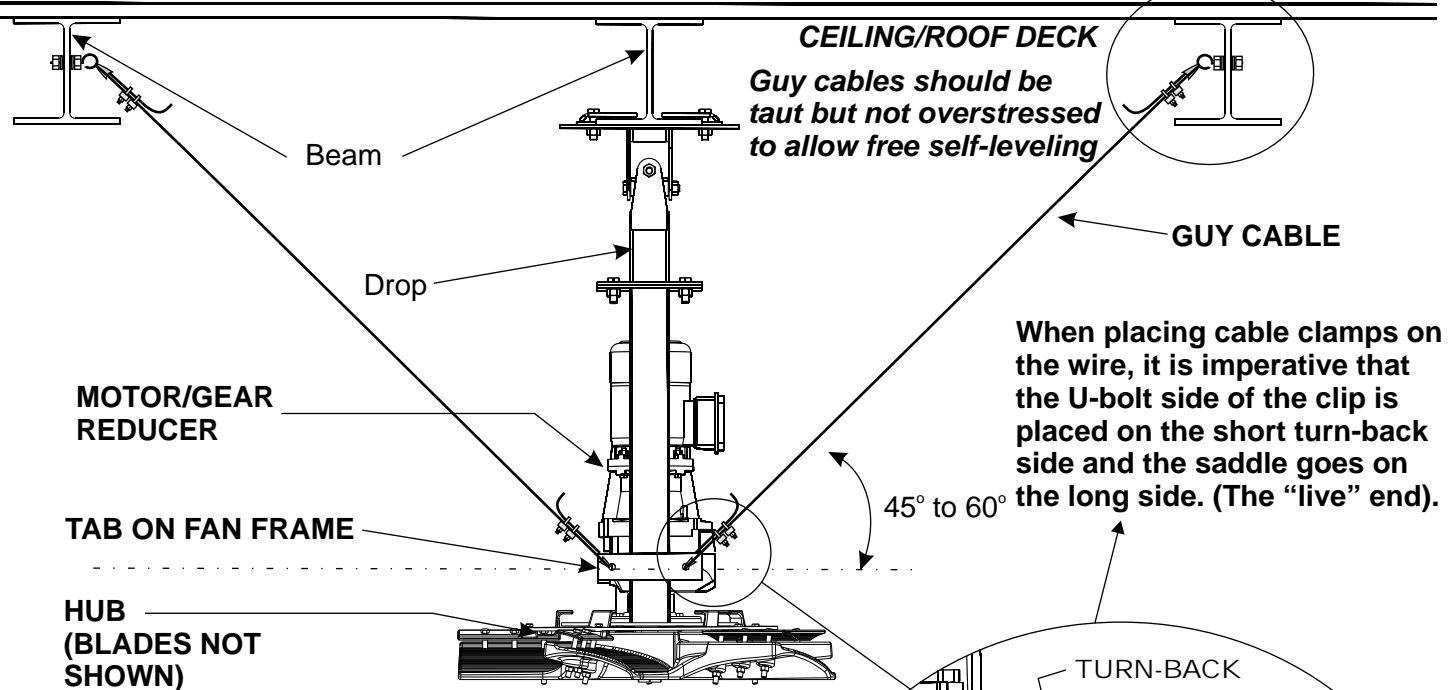

Fig. 15

STRUCTURAL NOTE: Guy cables must be installed or fastened to a structural component of the building at the angle shown in Fig.15 and Fig.17.

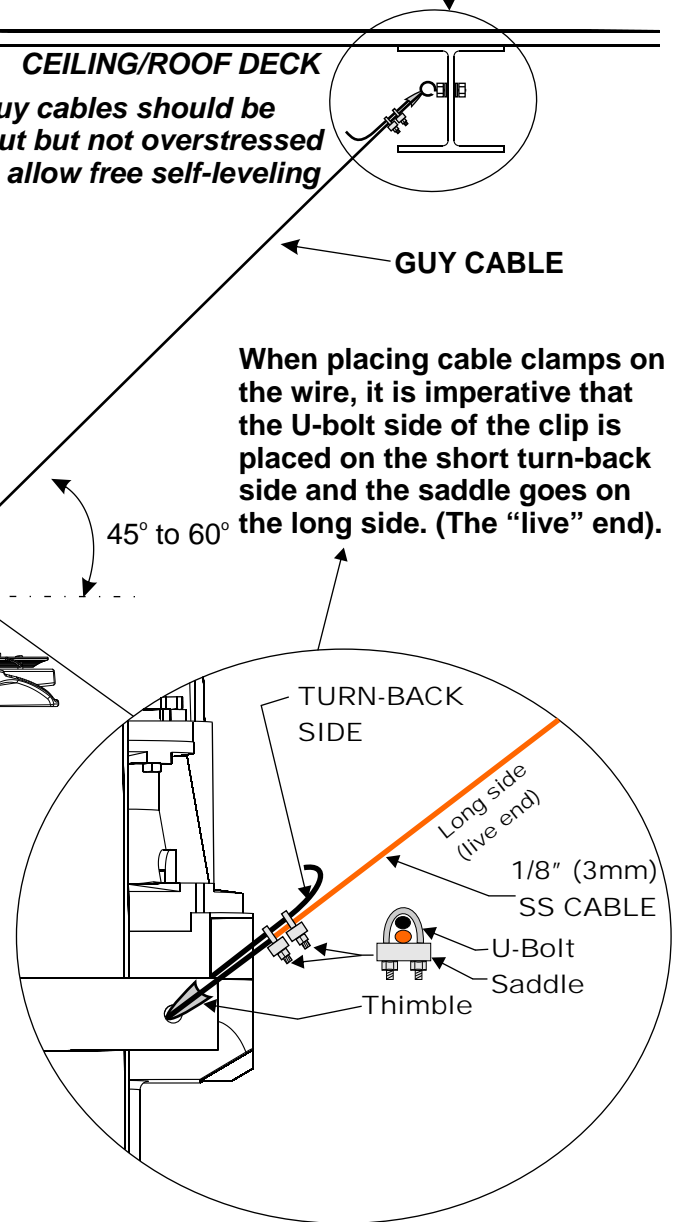
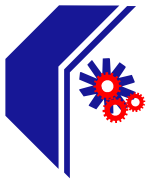

Fig. 16



Installing Guy Wires

1. Determine mounting position on ceiling and establish the angle between 45°- 60° for the cable. Determine correct location on the I Beam to drill 8mm diameter hole for the eye bolt. For example, if fan is 1.2m down from ceiling, cables should be mounted approximately 1.2m away from fan.
2. Install eye bolt with nuts and washers in I Beam as per Fig.15.
3. Measure the run of cable required and cut cable approximately 0.6m longer. **NOTE:** longer runs than 4.5m will require additional cable.
4. Secure it with 1 thimble and 2 cable clamps (Fig.16). Repeat using the other 3 pieces of guy wire cables, thimbles and cable clamps (Fig.16).
5. Guy wires should be taut but not overstressed to allow free self-levelling. They should also be approx. 90° apart (Fig.17).
6. **Check to see if the fan is level by placing your level vertically on the side of the fan frame. If adjustment is needed, slightly tighten the guy wires on proper side.**

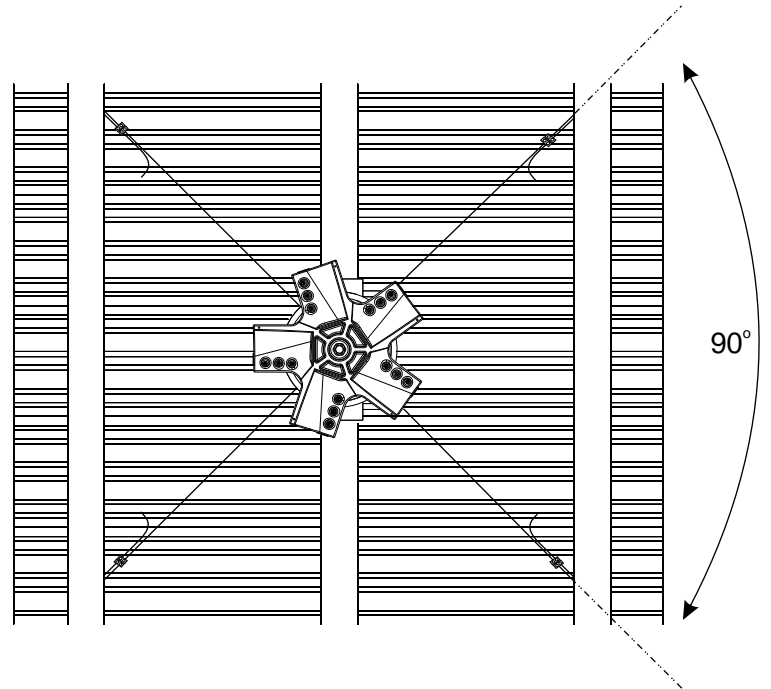

Fig.17

NOTE: Fans hanging lower than 3m from where the guy wires will mount will require additional cable.

8/ Blade Assembly

The assembly includes:

- (5) Blades
- (5) Blade toppers
- (10) Bolts M10-1.5 x 90mm
- (5) Bolts M10-1.5 x 100mm
- (15) Nylocks M10-1.5
- (30) Washers Flat M10

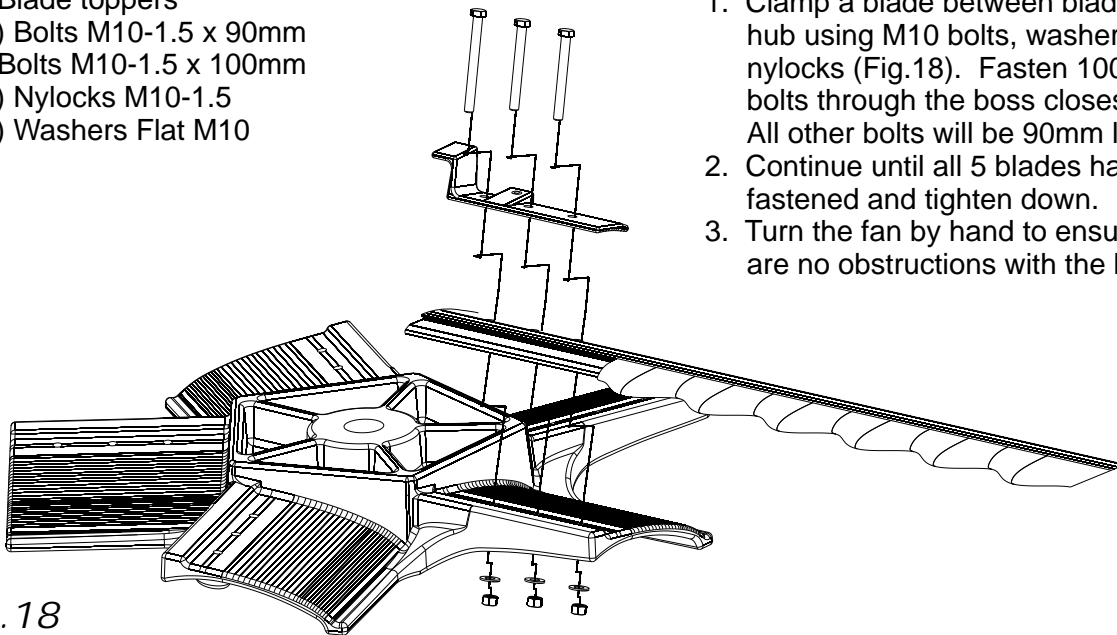
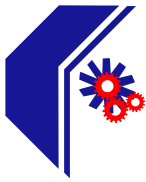

Fig.18

Installing the Blade Assembly

1. Clamp a blade between blade topper and hub using M10 bolts, washers and nylocks (Fig.18). Fasten 100mm long bolts through the boss closest to the hub. All other bolts will be 90mm long.
2. Continue until all 5 blades have been fastened and tighten down.
3. Turn the fan by hand to ensure that there are no obstructions with the blades.



9/ Safety Ring

The assembly includes:

- (1) Safety Ring (5 pieces)
- (5) Bolts 5/16" x 1" UNC
(use 13mm metric wrench to tighten)
- (5) Washers Flat M8
- (5) Washers Lock M8

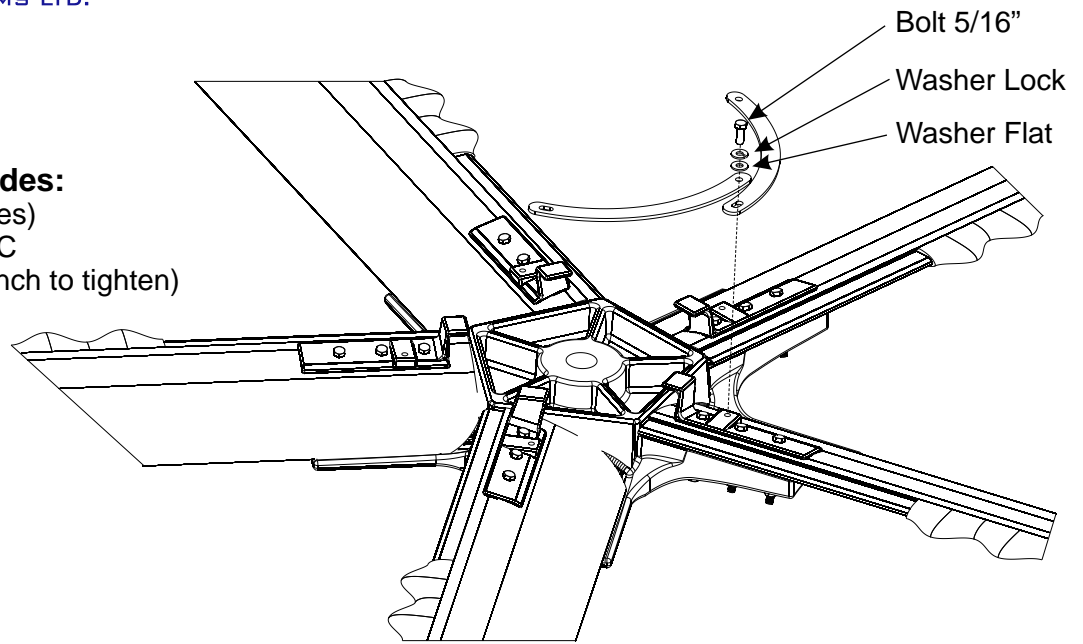
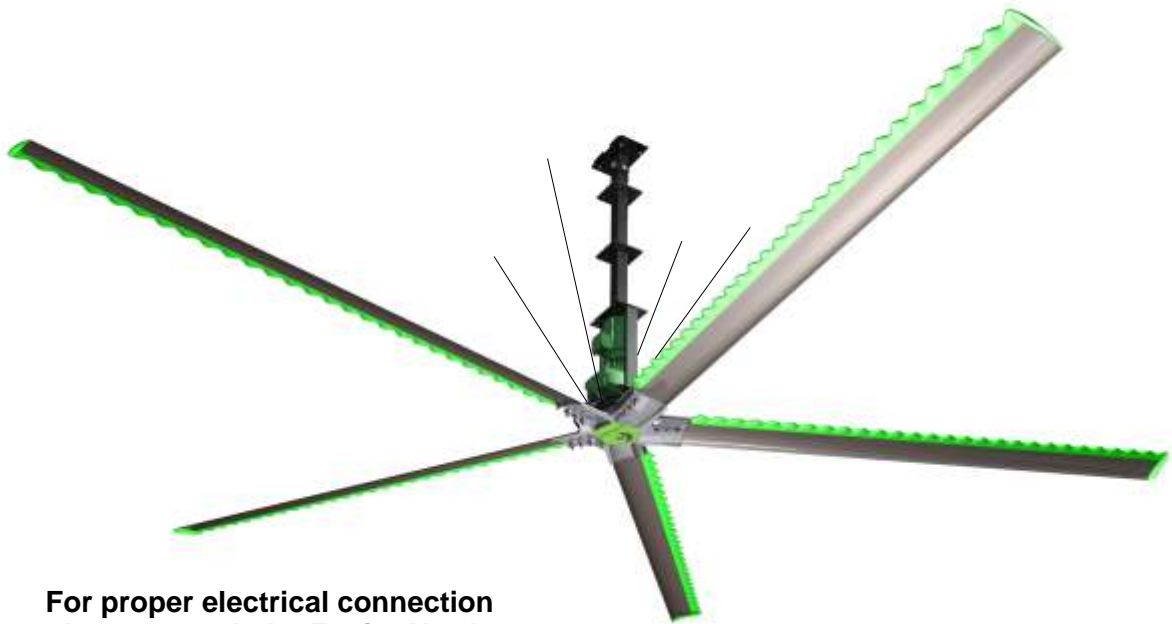

Fig.19

Installing the Safety Ring

1. Take 2 pieces of the safety ring, match the hole on one piece with the slot of the other piece, finger tighten the parts in place using M8 bolts and washers (Fig.19).
2. Continue to install all pieces until they are in place and form a continuous ring. Tighten all bolts with the proper tools.
3. **After your fan is installed, check the level again by placing your level vertically on the side of the fan frame. If adjustment is needed slightly tighten the guy wire on the appropriate side.**
4. Once levelled your fan is installed and ready for electrical installation / connection.



**For proper electrical connection
please consult the Envira-North
Electrical Installation Manual.**

Fig.20

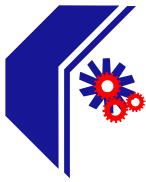

Itemized Checklist

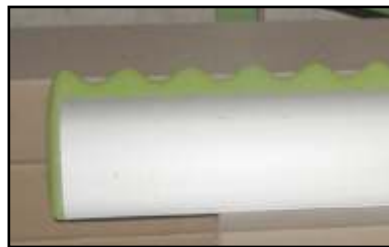
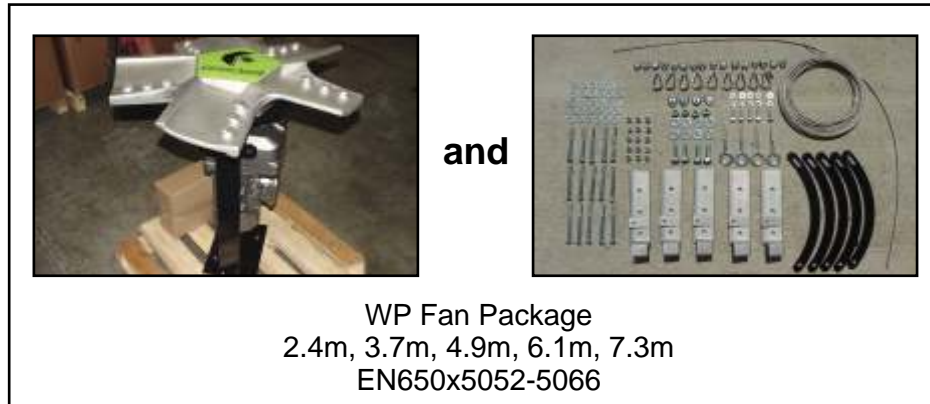

Control Options



Mounting Options



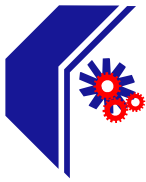

Recommended Maintenance Schedule

1. No maintenance shall be done on the fan, mount or guy wires while it is in operation or powered.
2. No maintenance shall be done on the fan controller while powered unless the task involves reprogramming or troubleshooting the electrical system.
3. No maintenance shall be done within a 6m horizontal radius of the fan and 1.2m below and none above the blade level while it is in operation.
4. While doing maintenance on the fan, mount, or guy wires, a safety barrier shall be erected at a radius of 6m of the centre of the fan.
5. The fan controller shall be locked out while maintenance is ongoing on the fan, mount, or guy wires.
6. All personnel working on the fan, mount, or guy wires, shall wear the appropriate personal safety equipment as mandated by local, provincial, and national regulations.
7. A risk assessment shall be performed before any maintenance is done on the fan, mount, guy wires and fan controller.
8. A tailboard meeting shall be performed before any work is done. A checklist shall be completed and shall include any emergency contacts for the area.

Power Unit

Motor

Our motor or gearmotor manufacturers supply Envira-North with motors/gearmotors built for our application. Designed for use with variable frequency drives; they are wound with 200°C moisture resistant Inverter Spike Resistant (ISR) magnetic wire which dramatically extends the life of the motor compared to motors with non-ISR wire. They have a three year limited warranty.

Maintenance Schedule

Initial Six Months

- Check for hot spots
- Re-tighten all loose electrical connections

Repeat Every Eighteen Months Thereafter

Gear Reducer/Gearmotor

Ultra-Air Fans are driven through Nord Helical Gear Reducers/Gearmotors. Nord is the best gear reducer for our particular application in terms of precision, durability, efficiency, reliability and quiet operation. They have a three year limited warranty.

Maintenance Schedule

Initial Eighteen Months

- Check oil level

Every Three Years Thereafter

- Replace oil with Shell Omala 220 or recommended equivalent as specified on gear reducer/gearmotor (acceptable oil fill level is within 10mm - 12mm or closer to the fill level plug).

Blades

The airfoil blades are designed for maximum efficiency and quietness with a minimum air disruption directly below the fan. All our blade shapes are extruded from 6063-aluminum alloy and heat-treated to T-5 condition. They are anodized to .0004 10 Microns clear for corrosion resistance and ease of cleaning. The blades have a lifetime warranty.

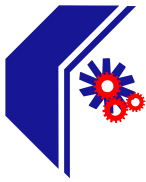

Recommended Maintenance Schedule Continued

Maintenance Schedule

Initial Six Months

- Ensure blades are intact, level and clean as required

Every Eighteen to Thirty-Six Months Thereafter

Drop/Mounting

The drop and mounting system is designed to prevent vibration or horizontal movement from being transferred back into the building structure. The system is easily installed in almost any building and allows fans to hang level from beams.

Maintenance Schedule

Initial Six Months

- Physical check of fan guy wires, re-tightening of clamps if required
- Check all nuts/bolts/clamps (missing/loose/damaged)
- Physical check of safety cable, re-tightening of clamps if required

After Eighteen Months Thereafter

Control Panel

Altra-Air controls are variable frequency drives which provide soft start/stop, variable speed control and overload protection for the motors. The VFD also allows fan control to be automated and/or integrated with other systems. The controls come with a three year limited warranty.

Maintenance Schedule

Initial Twelve Months

- Check for loose/discoloured wires
- Check for hot spots
- Re-tighten all loose electrical connections

Every Eighteen Months Thereafter

NOTE: Maintenance schedule is based on running 5,000 hrs / year and is a guide line to ensure safe and continuous operation of the fan(s). In case of extreme operating (e.g. high humidity, aggressive environment or large temperature variations), shorter intervals between service is recommended.

Safety Precautions

1. Safety cable installed as per Fig.11 in the *Altra-Air Fan Installation Guide*.
2. Guy wire installed as per Fig.15, Fig.16 and Fig.17 in the *Altra-Air Fan Installation Guide*.
3. Blade toppers and safety ring installed as per Fig.18 and Fig.19 in the *Altra-Air Fan Installation Guide*.
4. See next page for required clearances.
5. If installed in storage facility between racks, signs must be installed identifying fan locations.
6. The motor has thermal protection in case of overheating.
7. The variable frequency drive has several safety devices such as current limit, motor overload, minimum and maximum speed control. The controller also features a Stop button for emergency stoppage.

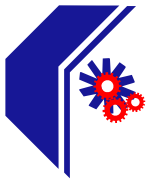

Ultra-Air Fan Clearance Requirements

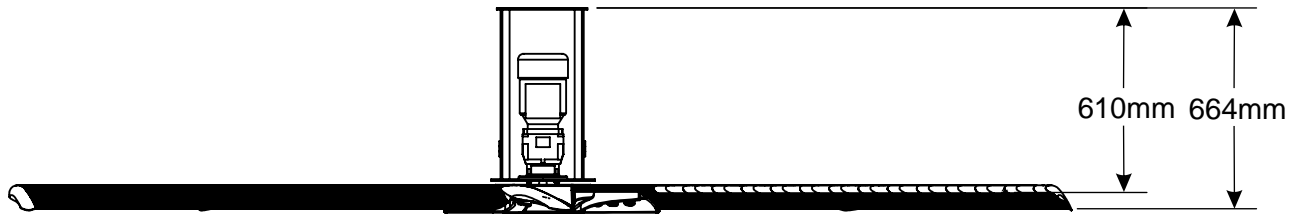

Fan Frame Detail

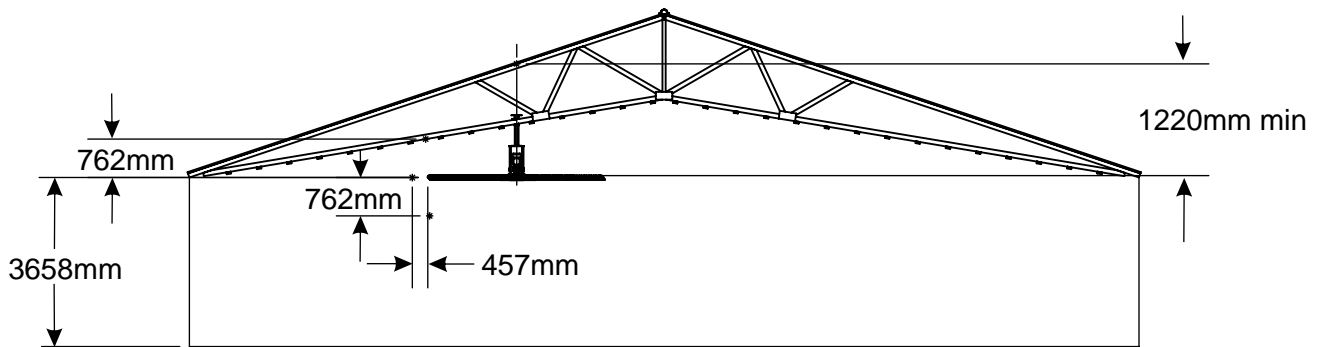

Sloped Roof

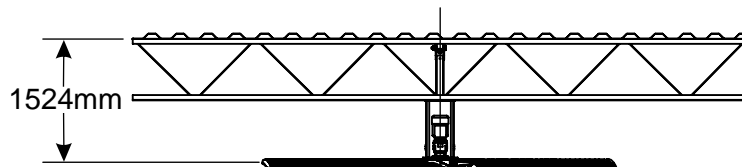

Flat Roof

Clearances

- Min 1524mm center of fan to roof deck for ideal operating performance without compromising overall fan performance
- Min 762mm from fan blade's leading edge to obstruction above or below fan
- Min 457mm from side of fan to any obstruction
- Min floor to fan leading edge height

Contractor is responsible for verifying all site conditions to include field dimensions where applicable. If the contractor elects to make any changes without notifying Envira-North Systems Ltd the contractor is responsible for the same. All drawings are to be used as general architectural intent unless otherwise stamped. See Engineer drawings for structural design information. Contractor to ensure that all building departments and authorities are informed in regard to the work and that all permits are attained before commencing work.

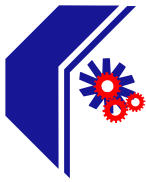

Recommended Maintenance Checklist

Fan Size:

Fan Size:

Fan Size:

Serial #:

Serial #:

Serial #:

Location:

Location:

Location:

Date	Initials

Date	Initials

Date	Initials

Limitation of Warranty and Liability

The Altra-Air fans are of industrial grade construction and should provide many years of virtually maintenance-free use. Warranty duration is as follows:

a)	Air foil shaped Blade	lifetime warranty
b)	Aluminum alloy hub	lifetime warranty
c)	Motor	3 year limited warranty
d)	Gear Reducer	3 year limited warranty
e)	VFD Control Panel	3 year limited warranty
f)	Labour	1 year limited warranty

Envira-North warrants that this product will, under normal use and service as specified by Envira-North, operate properly and be free of defects in materials and workmanship for a period of three years from the date of purchase by customer. The term “operate properly” in this context applies to mechanical, electrical and structural functions only. No guarantee, unless and except by separate written agreement, is made regarding dimensions of air movement generated or the effectiveness of this product for its intended purpose.

Labour warranty will cover all reasonable costs paid by the customer to an independent contractor (including dealers) to remove, dismantle, reassemble or reinstall any of the warranted products during the first year that the product is in service. All receipts are to be submitted to Envira-North which will be paid upon completion of the installation of the product and after the return of the failed unit. Envira-North will only issue a credit / cheque to the customer / dealer and will be not held responsible for paying the independent contractor.

Warranty Exclusions

Please note that the following may or could void any or all of the above listed warranties.

- Not following required installation procedures as in installation guide and all other documentation supplied with the fans and related equipment supplied by manufacturers of individual fan and control components.
- Not following all relevant codes and ordinances, not limited to National Electrical Code, provincial or state and local building codes.
- Not following electrical engineering industry standards regarding approved method of installing solid-state electrical equipment having characteristics of fans and all components included in this product.
- Any modification to installation, product, controls without written authorization from Envira-North, even if attempting to diagnose and / or repair a problem.
- Misuse, abuse, accidents, unreasonable use or Acts of God.
- Incorrect electrical current, voltage or supply
- Running fans at higher than recommended speeds.
- Re-setting parameters of any control without prior approval from Envira-North.
- Failure to use all installation and mounting hardware supplied by Envira-North.
- Failure to perform periodic maintenance as detailed in the Envira-North installation guide.

Limitation of Warranty and Liability

Envira-North reserves the right to make the final determination, based on its own evaluation of the components as to whether:

- The problem in question is the result of a defect in design, workmanship or materials and not the result of error, misuse or abuse on the part of the customer as stated above.
- Whether the problem or defect is material and requires action under this warranty.
- Whether the remedy of repair or replacement is appropriate.

Envira-North will not be responsible for remedial work necessary to correct installation procedures that do not conform to those established by the instructions, codes and standards, regardless of when the installation occurred.

With regard to electrical and electronic components provided by Envira-North that comprise part of the products, including motors, motor drives and variable frequency drives, Envira-North relies on the determination by the original manufacturer as to whether the failure of such component was the result a defect. If the manufacturer of such component determines that there was no defect and therefore refuses to cover it under warranty, Envira-North likewise will not warranty such item unless Envira-North determines that the failure of such electrical or electronic component was the result of a defect of design, workmanship or material within some other part of the products.

Warranty Duration

With respect to replacement or repair rendered, Envira-North warrants that the parts replaced or repaired will operate properly and be free from defects in materials and workmanship for a period of 90 days from the shipment date of the replacement products to the customer, or for the remainder of the original warranty period, whichever is longer.

Warranty Claim Instructions

1. Contact your original dealer / salesman of the purchase when you first notice problem with the product.
2. It will be the responsibility of the dealer or salesman to assist the customer in determining what product is causing the problem.
3. If they cannot diagnose the problem, they are to contact Envira-North with all the necessary information.
4. The appropriate department will then be in contact with the customer to determine the cause of the problem.
5. Once diagnosed, submit a Purchase Order for a replacement unit complete with price.
6. A replacement unit will be shipped out upon receipt of the PO. This PO allows for an order to be established in the Envira-North System.
7. Once the units have been changed over, submit all reasonable costs to Envira-North for payment.
8. No credits or cheques will be issued until all original products are received back at Envira-North or unless Envira-North directs otherwise.

DECLARATION OF CONFORMITY

according to the
**Safety of Machinery Directive (98/37/EC),
 Low Voltage Directive (2006/95/EC), Electromagnetic Compatibility Directive (2004/108/EC),
 and including amendments by the CE Marking Directive, 93/68/EEC**

Type of equipment: *Industrial Ceiling Fans*
Type designation: *Series #EN6XXX*
Manufacturer: *Envira-North Systems Ltd
 92 Railway Street
 Seaford, ON N0K 1W0
 Canada*

The following harmonized European standards or technical specifications have been applied:

<u>Standard</u>	<u>Subject</u>
ISO/TR 12100-1: 2003	Safety of Machinery - Basic Concepts, General Principles for Design - Part 1: Basic Terminology, Methodology.

With reference to the Safety of Machinery Directive:

The product complies with good engineering practice in safety matters within the EU, even though it may not fully comply with the safety standards/specifications listed above, (see Technical Construction File). The product is CE marked in year 2010. Envira-North Systems Ltd. has an internal production control system and formal quality control process that ensures compliance between the manufactured products and the technical documentation.

With reference to the EMC Directive:

Full utilization of CE Certified or equivalent equipment.

With Reference to the Low Voltage Directive:

Full utilization of CE Certified or equivalent equipment.

As manufacturer/manufacturer's authorized representative, we declare under our sole responsibility that the equipment follows the provisions of the Directives stated above (this Declaration of Conformity and its associated Technical Construction Files shall be retained and valid for a minimum of ten years following the below Date).

CE

10

Signing Authority:

Wanneste

Date:

June 25/10

Cathy Wanneste
 Senior Administrator
 Envira-North Systems Ltd.

Prepared By:

Paul M. Johnson

Date:

June 20/10

Paul M. Johnson, C.E.T., ASQ
 President
 Neoteric Enterprises Inc.